

Single & Dual 3.7 Gallon Margarita Machine Instructions

Making The Mix

1. Use a clean bucket or pot that is capable of holding 2 ½ gallons of liquid.
2. Pour into the bucket, one ½ gallon bottle of mix.
3. Using the same bottle, add four more bottles of water, this will give you 2 ½ gallons.
4. If you want alcohol in your mix, add it now. It takes about **25 ounces (1/5th Bottle) of alcohol** per 2 ½ gallons of mix.
5. Stir mixture thoroughly.
6. It is helpful to refrigerate any extra mix. This helps speed the slushing process.

Using The Machine

1. Place margarita machine on a sturdy table or counter.
2. Remove the top off the tank that you are going to fill first
3. Pour mixture into the tank until it reaches the max line. **DO NOT FILL THE TANK ABOVE THAT MARK!**
4. Place the top back on the machine.
5. Turn the main power switch on (See diagram below).

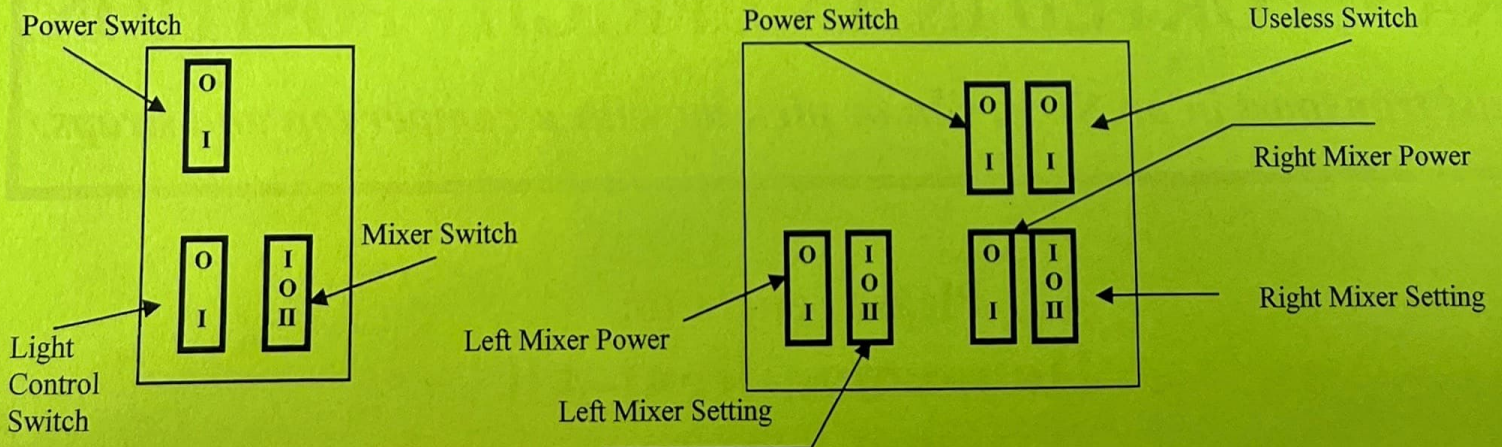
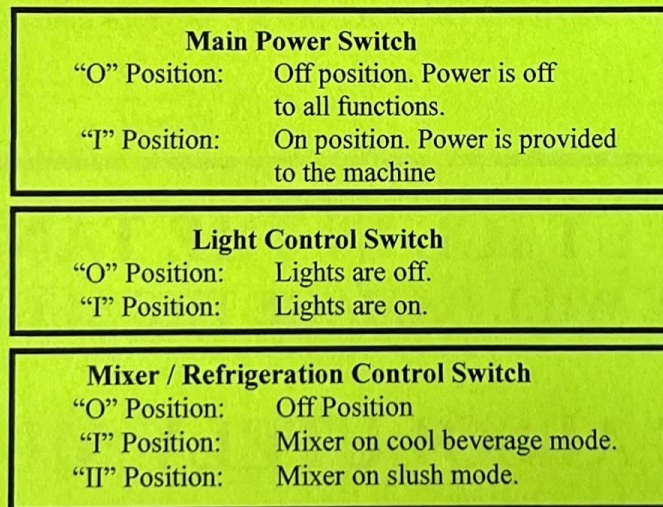

Single Tank Switches

Dual Tank Switches

Using The Machine

6. Turn the mixer / refrigeration switches on for one or both tanks.
7. Turn the light control switch on if you want the tops to be lighted.
8. It will take approximately 60 minutes for non-alcoholic mixture to turn to slush, and about 1½-2 hours for mixture with alcohol to slush.
9. **NEVER - NEVER - NEVER** run the machine without the mixers turning when it is in slush mode. (Slush mode is designated by the * snowflake symbol).
10. If you plan on serving large volumes of mix, it is helpful to refill mix into the tanks when they are depleted to the half way point. This helps speed the slushing process up.
11. It also helps to refrigerate mix whenever possible. This will also speed up the slushing ability of the machine.
12. When you are done serving slush drinks turn machine off. Once the slush thaws, drain remaining mixture from machine.
13. Do not touch the timer on the side of the machine, this could prevent the machine from freezing.
14. Do not attempt to take the machine apart.
15. **DO NOT TRY TO ADJUST SETTINGS ON THE REAR OF THE MACHINE!!!**

**** Do not allow tanks to empty while the compressors are on!**

Please note, these machines can be used to keep juices cold too. They are great for cold lemonade or orange juice etc.

**DO NOT PUT ICE IN THE TANKS!
ADDING ICE WILL DAMAGE THE AUGERS**

*** MACHINE ABSOLUTELY MUST BE
TRANSPORTED IN AN UPRIGHT POSITION.**

Must transport in an SUV, van or pick up with a camper top and straps.